

# Technical data sheet

## Wall and support bracket AW 15 2L

Item number: 6420924



Wall and support bracket with welded head plate and two fastening holes.  
The double-perforated bracket offers the special option of double anchoring on lightweight partitions and light masonry.



**St** Steel

**FT** Hot-dip galvanised

### Master data

Item number	6420924
Type	AW 15 51 FT 2L
Description 1	Wall and support bracket
Description 2	with 2 fastening holes
Manufacturer	OBO
Dimension	B510mm
Material	Steel
Surface	Hot-dip galvanised
Surface standard	DIN EN ISO 1461
Smallest sales unit	1
Unit of quantity	Piece
Weight	72 kg
Weight unit	kg/100 pc.

# Technical data sheet

## Wall and support bracket AW 15 2L



Item number: 6420924

### Dimensions

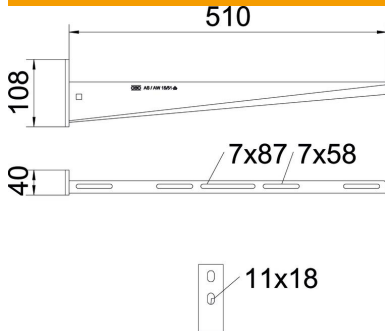

Length	40 mm
Width	510 mm
Width	20 in
Height	108 mm
Height	2.83 in
Dimension A	40 mm
Dimension B	510 mm
Dimension H	108 mm

### Technical data

Version for	Wall and support bracket
F in kN	1.5 kN
Maintain electrical functions	no
Hole diameter	11 mm
Rustproof steel, pickled	no
Angle range, max.	90 mm
Angle range, min.	90 mm

### Loads

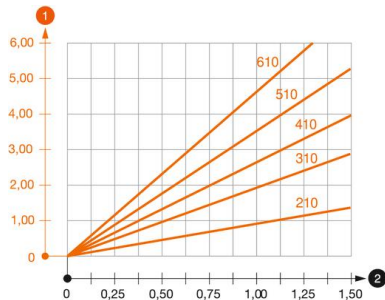

#### Load diagram, bracket, type AW 15

- 1** Bending of the bracket tip at permitted bracket load
- 2** Permitted bracket load in kN without man load
- Load curve with bracket lengths in mm

### Characteristic anchor load values for wall bracket AW 15

Anchor type	Wall fastening							
	Max. load [kN]							
	Bracket width [mm]							
	110	160	210	310	410	510	560	610
BZ3 10x90/0-30	1.5	1.5	1.5	1.47	1.25	1.13	0.95	0.94

Die angegebenen Werte basieren auf ungerissenen Beton der Festigkeitsklasse C20/25. Die Einbaubedingungen der ETA-Zulassung (Dübel) sind zu beachten!