

# Technical data sheet

UGD250-3 for rectangular installation units, for screed height 70–125 mm  
Item number: 7410083

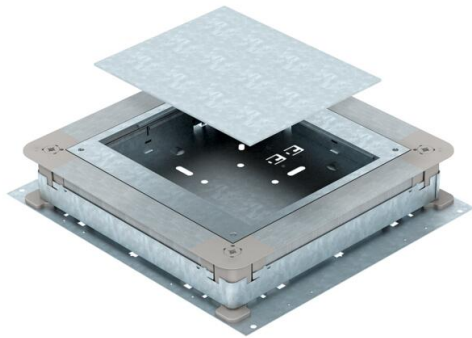

Underfloor accessory box for screed-covered underfloor installation ducts with sheet steel side walls. To mount installation units of the selected nominal size. Height can be infinitely adjusted to the nominal screed height (rapid adjustment possible) and the screed can be worked flush to the screed scraping edge. With noise decoupling option after screed laying and can be used with system accessories, also for heavy-duty application. Side walls are prepared for duct widths 190 and 250 mm.



- St** Steel
- FS** Strip galvanized

## Master data

Item number	7410083
Type	UGD 250-3 6
Description 1	Underfloor box empty
Description 2	250-3 for GES6
Manufacturer	OBO
Dimension	410x367x70
Material	Steel
Surface	Strip galvanized
Surface standard	DIN EN 10346
Smallest sales unit	1
Unit of quantity	Piece
Weight	584 kg
Weight unit	kg/100 pc.

# Technical data sheet

UGD250-3 for rectangular installation units, for screed height 70–125 mm

Item number: 7410083



## Dimensions

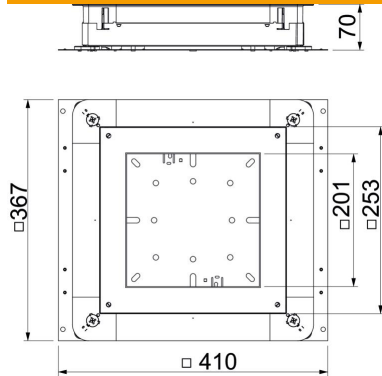

Dimension a	201 mm
Dimension A	367 mm
Dimension B	410 mm
Dimension b	253 mm

## Technical data

Floor plate	yes
Lowerable to be flush-floor	yes
Seal installation option	yes
Installation opening for on-floor tank	no
Installation opening for flush-mount unit	Rectangular
Decouplable	yes
Screed height, max.	125 mm
Screed height, min.	70 mm
For pipe connection	no
Suitable for screed-flush closed underfloor ducts	no
Suitable for screed-covered underfloor ducts	yes
Suitable for underfloor ducts	no
Installation space, max.	11.63 dm <sup>3</sup>
Installation space, min.	6.09 dm <sup>3</sup>
Trunking width, max.	250 mm
Trunking width, min.	190 mm
Trunking height, max.	48 mm
Duct height, min.	28 mm
Minimum screed height	70
Nominal size	250 mm
Nominal size for device installation units	6
Height-adjustment range, max.	125 mm
Height-adjustment range, min.	70 mm